

CDL / CDLF

Light Vertical Multistage Centrifugal Pump Installation & Operating Instructions



50 / 60Hz



Before beginning installation procedures, these installation and operation instructions should be studied carefully. The installation and operation should also be in accordance with local regulations and accepted codes of good practice.

1. Type Designation

See pump nameplate

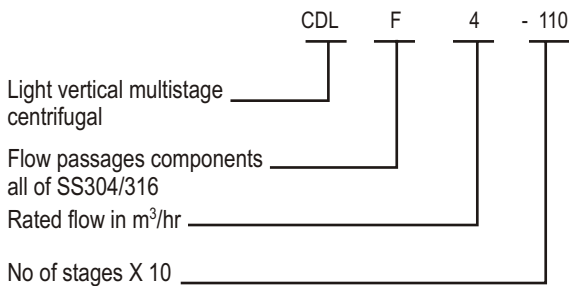

2. Applications

The CDL, CDLF multistage in-line centrifugal pumps are designed for the following applications:

- | Municipal water supply and pressure boosting
- | Domestic water supply
- | Boiler feed and condensate systems
- | Cooling water systems
- | Irrigation and dewatering
- | Fire fighting
- | Washing plants and Washdown
- | Water treatment plants
- | Reverse Osmosis systems

Pumped Liquid

Thin, non-explosive non-corrosive liquids, containing no solid particles or fibres.

When pumping liquids with a density and /or viscosity higher than that of water, motors with correspondingly higher outputs must be used, if required.

3. Technical Data

- | Ambient Temperature
Maximum +40°C
- | Liquid Temperature
-15°C to +120°C
- | Minimum Inlet Pressure
According to the NPSH curve
- | Maximum Inlet Pressure - See chart on page - 3
- | Electrical Data
See motor nameplate
- | Dimensions and Weights
see catalogue

MAX INLET PRESSURE

The maximum inlet pressure is shown in the table below. But the actual inlet pressure plus the value close pressure of the pump shall be lower than the max. allowable working pressure.

Model	Max inlet pressure
CDL, CDLF1	
CDL, CDLF1 - 20 ~ 1 - 80	6 [bar]
CDL, CDLF1 - 90 ~ 1 - 360	10 [bar]
CDL, CDLF2	
CDL, CDLF2 - 20	6 [bar]
CDL, CDLF2 - 30 ~ 2 - 110	10 [bar]
CDL, CDLF2 - 130 ~ 2 - 260	15 [bar]
CDL, CDLF3	
CDL, CDLF3 - 20 ~ 3 - 50	6 [bar]
CDL, CDLF3 - 60 ~ 3 - 290	10 [bar]
CDL, CDLF3 - 310 ~ 3 - 360	15 [bar]
CDL, CDLF4	
CDL, CDLF4 - 20	6 [bar]
CDL, CDLF4 - 30 ~ 4 - 100	10 [bar]
CDL, CDLF4 - 120 ~ 4 - 220	15 [bar]
CDL, CDLF8	
CDL, CDLF8 - 20/1 ~ 8 - 60	6 [bar]
CDL, CDLF8 - 80 ~ 8 - 200	10 [bar]
CDL, CDLF16	
CDL, CDLF16 - 20/1 ~ 16 - 60	6 [bar]
CDL, CDLF16 - 40 ~ 16 - 160	10 [bar]
CDL, CDLF32	
CDL, CDLF32 - 10-1 ~ 32 - 20 - 2	3 [bar]
CDL, CDLF32 - 20 ~ 32 - 40	4 [bar]
CDL, CDLF32 - 50 - 2 ~ 32 - 100	10 [bar]
CDL, CDLF32 - 110 - 2 ~ 32 - 140	15 [bar]
CDL, CDLF42	
CDL, CDLF42 - 10 - 1	3 [bar]
CDL, CDLF42 - 10 ~ 45 - 20	4 [bar]
CDL, CDLF42 - 30 - 2 ~ 45 - 50	10 [bar]
CDL, CDLF42 - 60 - 2 ~ 45 - 130 - 2	15 [bar]
CDL, CDLF65	
CDL, CDLF65 - 10 - 1 ~ 65 - 20 - 2	4 [bar]
CDL, CDLF65 - 20 - 1 ~ 65 - 30	10 [bar]
CDL, CDLF65 - 40 - 2 ~ 65 - 80 - 1	15 [bar]
CDL, CDLF85	
CDL, CDLF85 - 10 - 1 ~ 85 - 10	4 [bar]
CDL, CDLF85 - 20 - 2 ~ 85 - 30 - 2	10 [bar]
CDL, CDLF85 - 30 - 1 ~ 85 - 60	15 [bar]

MAX WORKING PRESSURE

Model	Curve number
CDL, CDLF1	
CDL, CDLF1 - 20 ~ 1 - 230	1
CDL, CDLF1 - 250 ~ 1 - 360	2
CDL, CDLF2	
CDL, CDLF2 - 20 - 150	1
CDL, CDLF2 - 180 ~ 2 - 260	2
CDL, CDLF3	
CDL, CDLF3 - 20 ~ 3 - 230	1
CDL, CDLF3 - 250 ~ 3 - 360	2
CDL, CDLF4	
CDL, CDLF4 - 20 ~ 4 - 140	1
CDL, CDLF4 - 160 ~ 4 - 220	2
CDL, CDLF8	
CDL, CDLF8 - 20/1 ~ 8 - 120	1
CDL, CDLF8 - 140 ~ 8 - 220	3
CDL, CDLF16	
CDL, CDLF16 - 20 ~ 16 - 80	1
CDL, CDLF16 - 100 ~ 16 - 160	3
CDL, CDLF32	
CDL, CDLF32 - 10 ~ 1 - 32 - 70	1
CDL, CDLF32 - 80 - 2 ~ 32 - 120	4
CDL, CDLF32 - 130 ~ 32 - 140	5
CDL, CDLF42	
CDL, CDLF42 - 10 - 1 ~ 42 - 60	1
CDL, CDLF42 - 70 - 2 ~ 42 - 90	4
CDL, CDLF42 - 100 - 2 ~ 42 - 130 - 2	5
CDL, CDLF65	
CDL, CDLF65 - 10 - 1 ~ 65 - 50	1
CDL, CDLF65 - 60 - 2 ~ 65 - 80 - 1	4
CDL, CDLF85	
CDL, CDLF85 - 10 - 1 ~ 85 - 50 - 2	1
CDL, CDLF85 - 50 ~ 85 - 60	4

The following figure shows the limitation of pressure and temperature, which shall be kept within the region as shown in the figure

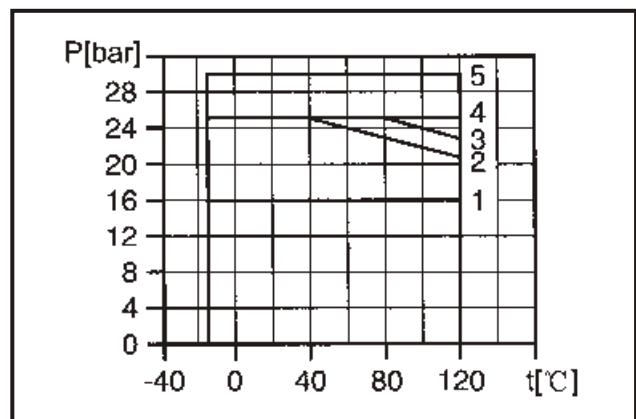

4. Installation

The pump should be installed with the motor shaft vertical, (see fig.1) Ensure that an adequate supply of cool air reaches the motor cooling fan.

Arrows on the pump base show the direction of flow of liquid through the pump.

Counter flanges, gaskets, bolts, PJE and CLAMP coupling sets are available as accessories and have to be ordered separately.

Fig. 1

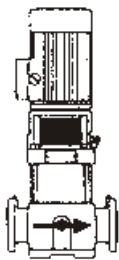

PJE and CLAMP coupling sets are available with threaded sockets or sockets for welding. Isolating valves should be fitted either side of the pump to prevent the system being drained if it is necessary to clean, repair or replace the pump.

Install the pipes in such a way that air locks are avoided, especially on the suction side of the pump. Correct pipework shown in fig.2.

Fig. 2

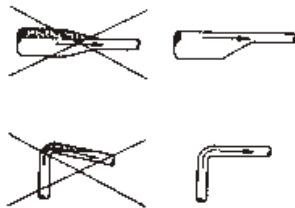

Care should be taken while fitting the pipes so that any tension caused by variations in temperature does not affect the pump.

If the pump is installed with long pipes, these should be adequately supported before and after the pump. If there is any risk of the pump being choked by sediments, leaves, twigs, etc., measures should be taken to prevent this, A strainer should be fitted at the suction side of the pump.

In the case of installations in which the discharge pipe has been installed horizontally, or it slopes downwards away from the pump, which can or must be drained in certain periods, the pump should be protected against dry-running. This can be done by fitting a loop with a vacuum valve close to the pump, see Fig. 3.

The highest point of the loop should at least be in level with the lower edge of the pump motor.

The discharge pipe can then be drained independently of the pump and vice versa.



The pump should not be run with a closed discharge valve as this will cause an increase in temperature / formation of steam in the pump which may cause damage to the pump.

If there is any danger of the pump running with a closed discharge valve, a minimum liquid flow through the pump should be ensured by connecting a bypass/ a drain to the discharge pipe. The drain can be connected to a tank...

Fig.3

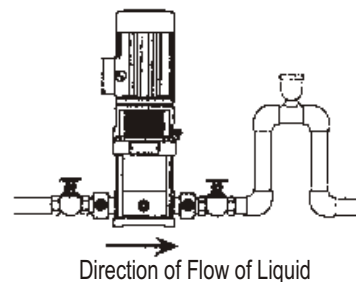

Minimum Flow Rates for CDL

Type	Liquid Temperature	
	-15°C to +80°C	+80°C to +120°C
CDL 2	0.2m ³ /h	0.2m ³ /h
CDL 4	0.4m ³ /h	0.4m ³ /h
CDL 8	0.8m ³ /h	0.8m ³ /h
CDL 16	1.6m ³ /h	1.6m ³ /h

5. Electrical Connections



Before removing the terminal box cover and before any removal / dismantling of the pump, make sure that the electricity supply has been switched off.

The electrical connections should be carried out by an authorized electrician in accordance with local regulations.

The pump must be connected to an external switch. The operating voltage and frequency are marked on the nameplate. Make sure that the motor is suitable for the electricity supply on which it will be used.

Single-phase motors incorporate a thermal switch and require no additional motor protection. Three-phase motors must be connected to a motor starter. The terminal box can be turned to four positions, in 90° step. If necessary, remove the coupling guards by means of screwdriver. Do not remove the coupling.

Remove the bolts securing to the motor and the coupling.

Turn the motor to required position. Replace and tighten the bolts. Replace the coupling guards. The electrical connection should be carried out as shown in the diagram inside the terminal box cover.



Do not start the pump until it has been filled with liquid.

6. Start-Up



Do not start the pump until it has been primed and vented.

┆ Priming

Closed or open systems where the liquid level is above the pump inlet:

Close the discharge isolating valve and loosen the vent screw in the pump head



Pay attention to the direction of the vent hole and take care to ensure that the escaping water does not cause injury to persons or damage to the motor or other components. In hot water installations, special attention should be paid to the risk of injury caused by scalding hot water.

Slowly open the isolating valve in the suction pipe until a steady stream of liquid runs out the vent hole. Tighten the vent screw and completely open the isolating valve(s).

Open systems where the liquid level is below the pump inlet:

The suction pipe and the pump must be filled with liquid and vented before the pump is started.

┆ Checking Direction of Rotation

Do not start the pump to check direction of rotation until it has been filled with liquid



The direction or rotation should not be checked with the motor alone, as an adjustment of the shaft position is required when the coupling has been removed.

The correct direction of rotation is shown by arrows on the pump head and/or on the motor fan cover.

┆ Starting

Before starting the pump, completely open the isolating valve on the suction side of the pump and leave the discharge isolating valve almost closed. Start the pump.

Vent the pump during starting by loosening the vent screw in the pump head until a steady stream of liquid runs out the vent hole,



Pay attention to the direction of the vent hole and take care too ensure that the



escaping water does not cause injury to persons or damage to the motor or other components. In hot water installations, special attention should be paid to the risk of injury caused by scalding hot water.

When the piping system has been filled with liquid, slowly open the discharge isolating valve.

While pumping liquid containing air, it is advisable to vent the pump regularly. To vent the pump, loosen the vent screw in the pump head during operation.

┆ Frequency of starts and stops

Motors smaller than 4KW should not start more than 100 times per hour.

Other motors should not start more than 20 times per hour.

7. Maintenance



Before starting work on the pump, make sure that no power is supplied to the pump and that it cannot be accidentally switched on.

Pump bearings and shaft seal are maintenance-free. If the pump is to be drained for a long period of inactivity, remove one of the coupling guards to inject a few drops of silicone oil on the shaft between the shaft seal faces from sticking.

Motor Bearings :

Motors which are not fitted with grease nipples are maintenance-free.

Motors fitted which grease nipples should be lubricated with a high-temperature lithium-based grease.

In the case of seasonal operation (motor is idle for more than 3 months of the year), it recommended to grease the motor when the pump is taken out of operation.

8. Frost Protection

Pumps which are not being used during periods of frost should be drained to avoid damage.

Drain the pump by loosening the vent screw in the pump head and by removing the drain plug from the base



Care must be taken to ensure that the escaping water does not cause injury to persons or damage to the motor or other components. In hot water installations, special attention should be paid to the risk of injury caused by scalding hot water.

Do not tighten the vent screw and replace the drain plug until the pump is to be used again.
 Before replacing the drain plug in the base, screw the bypass valve out against the stop.
 Fit the drain plug by tightening the large union nut followed by the bypass valve

9. Fault finding Chart



Before removing the terminal box cover and before any removal /dismantling of the pump, make sure that the electricity supply has been switched off.

Fault	Cause
1. Motor does not run when electric supply is started.	a) Supply failure. b) Fuses blown. c) Motor Starter overload has tripped out. d) Main contacts in motor starter are not making contact or the coil is faulty. e) Control circuit fuses are defective. f) Motor is defective.
2. Motor starter overload trips out immediately when supply is switched on.	a) One fuse is blown. b) Contacts in motor starter overload are faulty. c) Cable connection is loose or faulty. d) Motor winding is defective. e) Pump is mechanically blocked. f) Overload setting too low.
3. Motor starter overload tripped out occasionally.	a) Overload setting too low. b) Low voltage at peak times.
4. Motor starter has not tripped out but the pump does not run,	a) Check 1 a), b), d) and e).
5. Pump capacity not consistent.	a) Pump inlet pressure is too low. b) Suction pipe / pump partly blocked by impurities. c) Pump draws in air.
6. Pump runs but gives no water.	a) Suction pipe / pump blocked by impurities. b) Foot or non-return valve blocked in closed position. c) Leakage in suction pipe. d) Air in suction pipe or pump. e) Motor rotates in the wrong direction.
7. Pump runs backwards when switched off.	a) Leakage in suction pipe. b) Foot or non-return valve defective, c) Foot valve blocked in open or partly open position. d) Non- return valve leaks or is blocked in partly open position.
8. Leakage in shaft seal.	a) Pump shaft position is incorrect. b) Shaft seal is defective.
9. Noise	a) Cavitation has occurred in the pump. b) Pump does not rotate freely (frictional resistance) because of incorrect pump shaft position.

10. Maintenance

Under normal operating conditions, the pump does not require any maintenance.

If the pump has been used for pumping liquids that may leave impurities in the pump, it should be flushed through with clean water immediately after use.

11. Calculation of Minimum Inlet Pressure

The Minimum inlet pressure "H" in meters head required to avoid cavitation in the pump is calculated as follows:

$$H = P_b \times 10.2 - \text{NPSH} - H_f - H_v - H_s$$

P_b = Barometric pressure in bar.

(Barometric pressure can be set to 1 bar).

In closed systems P_b indicates the system Pressure in bar.

NPSH = Net positive Suction Head in metres head (to be read from the NPSH curve in the catalogue the highest flow the pump will be delivering).

H_f = Friction loss in suction pipe in meters head

H_s = Safety margin = 0.5 meters head.

If the calculated H is negative, an inlet pressure of minimum "H" meters head is required. There must be a Pressure equal to the calculated H during operation.

Example:

P_b = 1 bar

Pump type : CDL 16, 50HZ.

Flow rate : 16m³/h

NPSH : 1.5 metres head.

H_f = 3.0 metres head.

Liquid temperature : +90°C

H_v = 7.2 metres head.

$$H = P_b \times 10.2 - \text{NPSH} - H_f - H_v - H_s \text{ [m head]}$$

$$H = 1 \times 10.2 - 1.5 - 3.0 - 7.2 - 0.5 = -2.0 \text{ metres head.}$$

This means that an inlet pressure of 2.0 metres head is required during operation.

The pressure calculated in bar : $2.0 \times 0.0981 = 0.20 \text{ bar.}$

The pressure calculated in kPa : $2.0 \times 9.81 = 19.7 \text{ kPa.}$

PART LIST

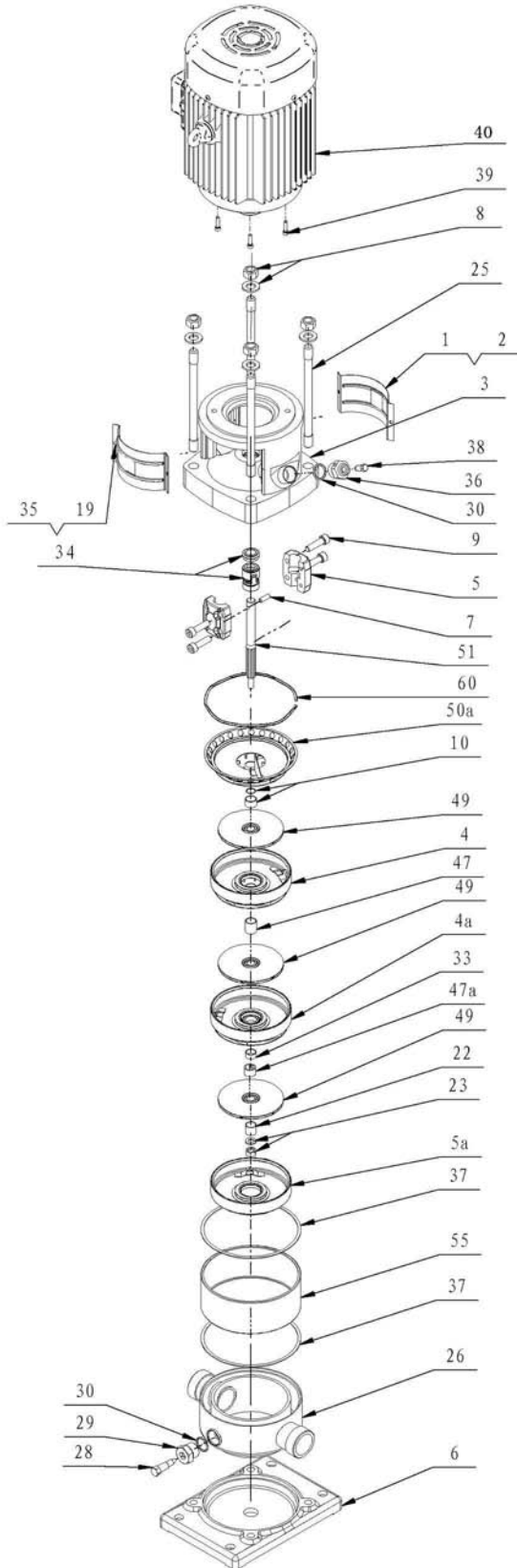

- 1. Cover
- 3. Motor base
- 4. Diffuser
- 4a. Support diffuser
- 5. Coupling (Bigger)
Coupling (Smaller)
- 5a. Inducer
- 6. Base
- 7. Pin
- 8. Nut M12
- 9. Screw (M8×25)
- 10. Circlip
- 22. Impeller cover
- 23. Nut M8
- 25. Rod/pcs
- 26. Suction & Discharge
- 28. Vent plug
- 29. Drainage
- 30. O-ring
- 31. O-ring (8×2.5)
- 32. Neck ring
- 33. Sleeve
- 34. MS (YEB-12)
- 35. O-ring (16×2.5)
- 36. Vent
- 37. Gasket
- 47. Sleeve
- 47a. Bush
- 49. Impeller
- 50a. Diffuser
- 51. Shaft
- 55. Cylinder
- 60. Spring

CDL, CDLF 1, 2, 3, 4

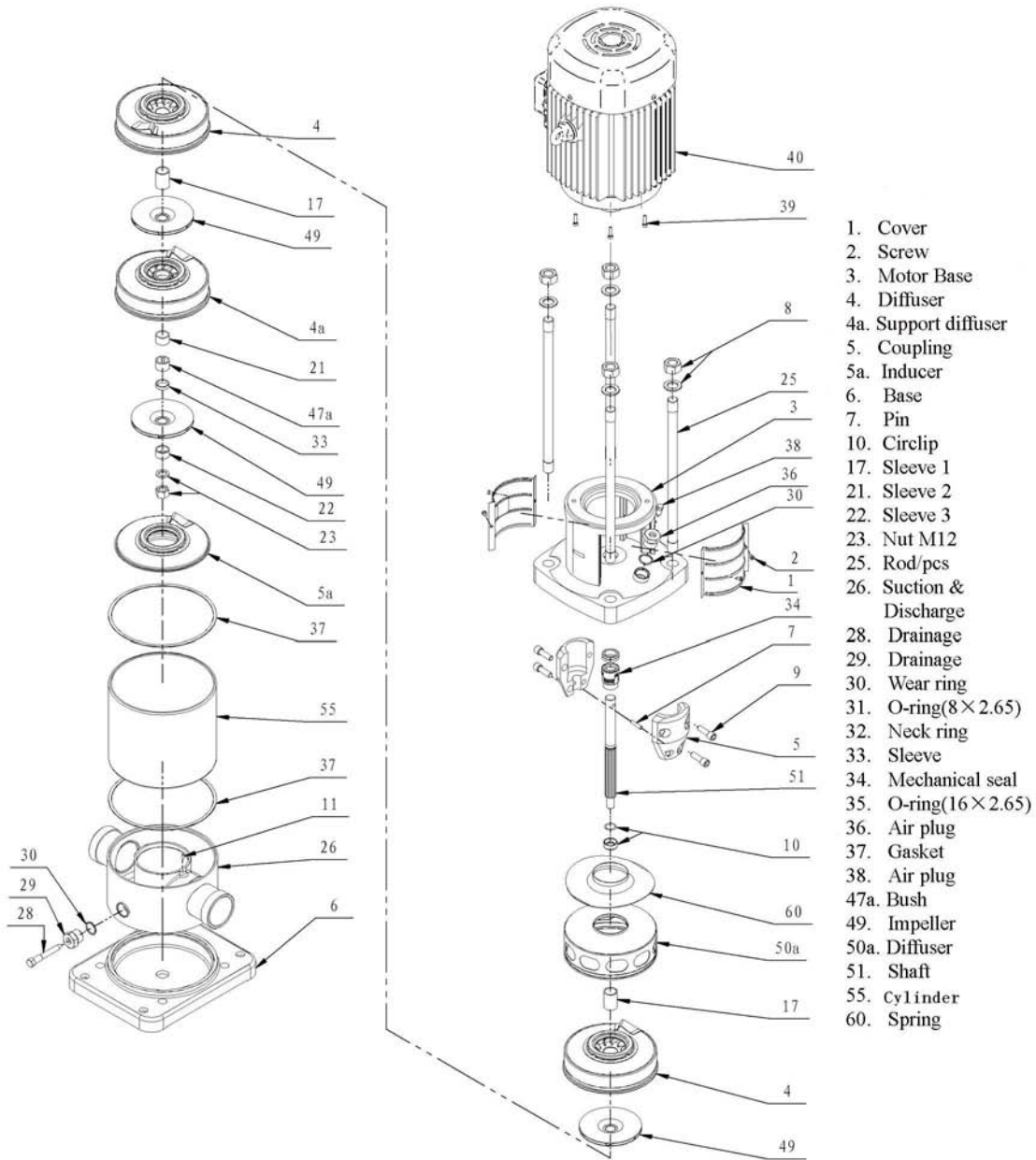

CDL, CDLF 8, 16, 20

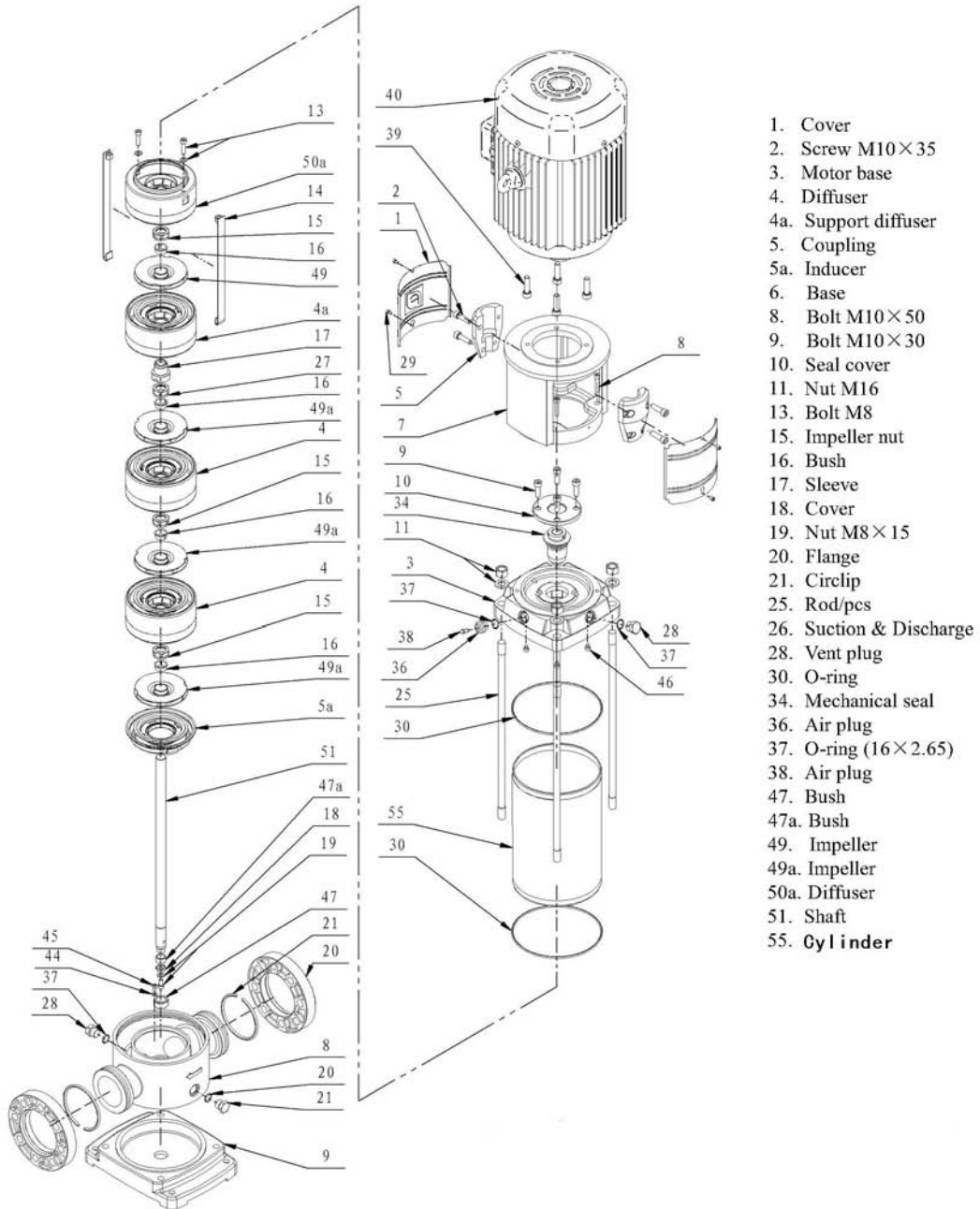

- 1. Cover
- 2. Screw M10×35
- 3. Motor base
- 4. Diffuser
- 4a. Support diffuser
- 5. Coupling
- 5a. Inducer
- 6. Base
- 8. Bolt M10×50
- 9. Bolt M10×30
- 10. Seal cover
- 11. Nut M16
- 13. Bolt M8
- 15. Impeller nut
- 16. Bush
- 17. Sleeve
- 18. Cover
- 19. Nut M8×15
- 20. Flange
- 21. Circlip
- 25. Rod/pcs
- 26. Suction & Discharge
- 28. Vent plug
- 30. O-ring
- 34. Mechanical seal
- 36. Air plug
- 37. O-ring (16×2.65)
- 38. Air plug
- 47. Bush
- 47a. Bush
- 49. Impeller
- 49a. Impeller
- 50a. Diffuser
- 51. Shaft
- 55. Cylinder

CDL, CDLF 32, 42

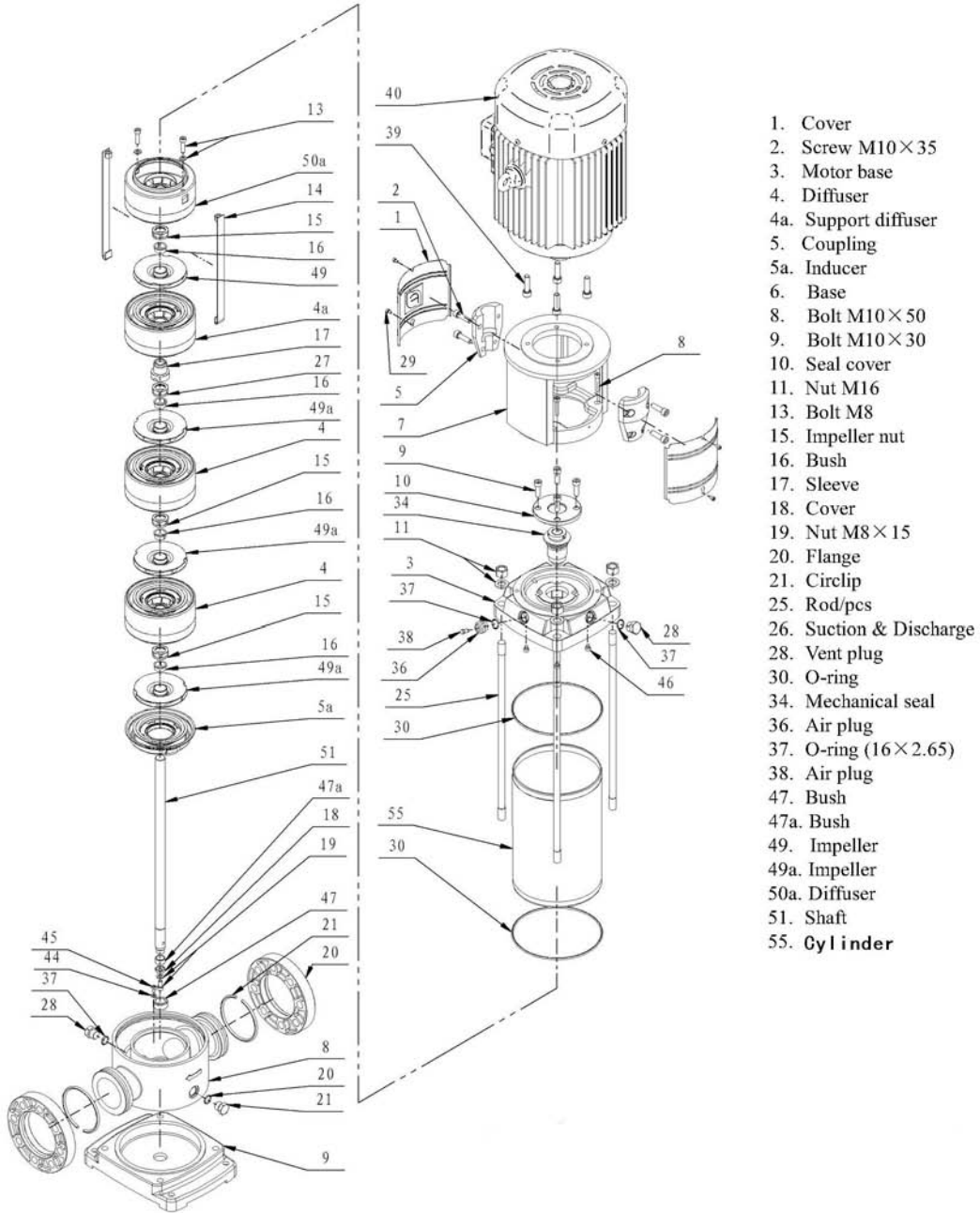

CDL, CDLF 65, 85



Agent / Distributor :